

BARANAGAR MUNICIPALITY

TENDER NOTICE NO: 90/PW/12-13

No: PW/90/1-12-13 Date: 19-2-13

M/s.....

SEALED Tender is invited and will be received by the **Chairman up to 3-00 P.M of 25-02-2013** for the following work as per terms and condition given below.

The Tender should be addressed to the Chairman, superscripted for " **CONSTRUCTION OF " JAL SATRA " IN DIFFERENT LOCATION WITHIN MUNICIPAL AREA "** "

DATE OF PURCHASE – **20.02.2013**

LAST DATE OF DROPPING- **25.02.2013**

SL. NO	WORK DESCRIPTION	TENDER AMOUNT Rs.	STIPULATED PERIOD FOR COMPLETION
01.	CONSTRUCTION OF " JAL SATRA " IN DIFFERENT LOCATION WITHIN MUNICIPAL AREA "	1,34,476.00	WITHIN 15 DAYS FROM ISSUE OF WORK ORDER.

5/19/13
EXECUTIVE OFFICER.

Chairman 19/2/13
CHAIRMAN.

TERMS & CONDITION:-

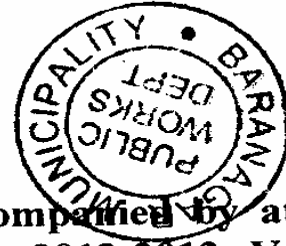

- 1. Application for tender papers should be accompanied by attested copies of current IT return for Assessment Year 2012-2013, Vat and Professional Tax registration certificate & up-to-date payment of Professional Tax challan, PAN Card, credential in form of payment and completion certificate including copy of work order of a single work (similar type) amounting of minimum 50 percent (50%) of the tender amount .No applications should be received after the scheduled date and time.**
- 2.The tender documents may be down loaded from the Municipal website and for that documents a payment of 200/- (Rupees two Hundred Only) in the form of Bank draft in favour of chairman, Baranagar Municipality, should be submitted, separately along separate requisite earnest money.**
- 3. Earnest money noted against the work @ 2.00% of the value of work mentioned in column-4 in the form of Demand Draft of Any Nationalized Bank in favour of Chairman, Baranagar Municipality, Shall have to be deposited during submission of tender. The earnest money of tenderer will be converted in to security money after acceptance. The security money will be released as per norms .No interest should be given on the earnest money & security money.**
- 4. Rate should be quoted in percentage basis, both in figure and in words.**
- 5. In connection with these works, no Arbitration will be allowed.**
- 6. Incomplete tender will rejected summarily. The successful tender will have to execute a formal agreement on a non judicial stamp worth 10/- within 7 (seven) days from the date of issue of work order.**
- 7. Before submission of tender, contractors must visit/inspect the work site at his own cost to judge the local situation/condition, approachable road etc. No plea/complain about the site, approach road etc .Shall be entertained afterwards. It shall be presumed that the agency offered the rate after taking into account the entire position of the work site ,approach road etc.**

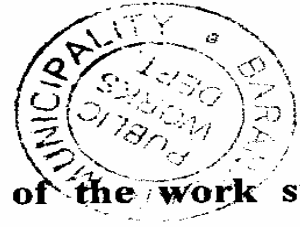

rate after taking into account the entire position of the work site ,approach road etc.

8. The offered rate should be inclusive of all sorts of incidental charges, levy, tax, cess, vat, carriage, loading, unloading, toll etc etc. No enhancement, additional claim arguments for escalation of price shall be allowed after submission the tender. No mobilization / secured advance will be allowed.

9. No mobilization/secured advance will be allowed.

10.No single tender shall include more than one work, but contractors who wish to tender for two or more works shall submit a separate tender for each.

11.The contractor shall have to carry out work with his own equipment and machinery.

12.After opening a tenders if required the authority may invite rates as authority desire.

13.The successful tender(s) shall have to start the work “within seven days” from the date of issuing of the work order and the work should be completed in with the stipulated time failing which the earnest money may be forfeited and this work order will be treated as cancelled.

14.Acceptance of lowest tender is not obligatory & the undersigned reserves the right to accept any tender or to reject any or all tenders without assigning any reason and to split up tendered work's to more than one contractor in the interest of speedy execution of the scheme.

15.The undersigned reserves the right to alter the terms and condition of this notice at any time in the interest of public service only.

16.Any above rate of the schedule rate of work will not be ordinarily entertained.

17. The item of work for which Tender is submitted should be clearly mentioned along with commensurate earnest deposit. The earnest money deposited will be forfeited by chairman, Baranagar Municipality in case:-

- (i) The tender withdraws tender after opening or acceptance.



- (ii) **The selected tender fails to accept order, refuses either wholly or partly the offer that would be made by the undersigned.**
- (iii) **The selected Tenderer fails to work or reply within the date stipulated in the work order.**

18. Schedule of work/supply will be prepared and measured as per approved P.W.D (W.B) schedule of Rates for Effective from 1st August 2010. 7th corrigendum Addenda & Errata of schedule of Rates for Road & Bridge works, 2008-2009 of P.W (Road) Directorate April-2012, W.E.F. 30.11.12.

19. The undersigned reserves the right to forfeit the Earnest money and security deposited in the event of any short of breach of contract.

20. Contractor should put their firms / organization endorsement (signature of authorized signatory with official stamp) on each page of the tender document as token of approval.

21. Contractor is note that non-compliance of any of the instruction is liable to render their tender non-bona fide.

22. All kinds of materials and labour related to the job will have to be arranged by the contractor and to be got approved by Engineer in charge or inspector before their use. The contractor at his own cost shall remove the rejected materials / workmanship from site within 24 hours.

23. The contractor at his own cost shall store all the materials which will be used for the work.

24. The quantities mentioned in the schedule of quantities approximately indicate the total extent of work, but may vary to any extent and some items may even be omitted. No claim whatsoever shall be entertained on this account.

25. If the Engineer in charge / authorized officer of employer finds that the works be delayed by reason beyond the control of the contractor, the Engineer in Charges will make a fair and reasonable extension of time for completion of the contract with the written approval of the undersigned.



26. The work within the premises the contractor shall obtain certificate about the satisfactory Completion of work from the Engineer in Charge and submit the same along with the bills.

27. The work should be done with the consultation of P.W.D of Baranagar Municipality.

28. Contractors have taken requisite "All Risk Insurance Policies" to cover workman under Workman Compensation Act, loss / damage caused by natural calamities / accidental collapse of partially completed work, materials and plant at site and for third party claims for injury / damages.

29. Before taking initiation of any extra item / excess quantity during the work , the same should be got approved by Engineer in Charge or Inspector.

30. Due to work at Hospital if any the Contractors / agencies will be responsible for work at emergency basis and urgently finishing the work.

31. After issuance of tender, Contractor should read carefully before submission the tender documents. No addition, alteration, omission, inclusion, deletion, amendment shall be allowed by any means.

32. A deduction of 1% cess for labour welfare as per Govt. norms in addition to normal deduction for IT and other purposes shall be imposed on every raise of bill /claim by the agency.

Chairman
Baranagar Municipality

Chairman
Baranagar Municipality

BARANAGAR MUNICIPALITY

87 Deshbandhu Road (E), Kolkata-700035
Phone no. 033 25771071 / 6595 / 0012, Fax no. 033 25771071

Estimate for Construction of JAL SATRA at different location within Municipal area.

Sl.No.	Description	Quantity	Unit	Rate	Amount
1	Filling in foundation or plinth by silver sand in layers not exceeding 150 MM as directed and..... complete including the cost of supply of sand.(Payment to be made on measurement of finished quantity page no.2 item no. 4A, /2012 $2.82 \times 2.40 \times .30 = 2.03$	2.03	cum	616.71	1251.92
2	Single brick flat soiling packed jhama bricks including preparation of bed as necessary with brick joints properly filled in and..... complete as per direction a) single brick flat soiling thickness 75 MM page no. 13 item no.1 /2012 $2.82 \times 2.40 = 6.77$	6.77	sqm	426.5	2887.41
3	ordinary Cement concrete (1:2:4) with graded stone chips(20MM size) excluding shuttering and reinforcement.page no 14 item no.5/ 2012 $2.82 \times 2.40 \times .10 = 0.68$ $4 \times (2.25 + 1.30) \times .30 \times .20 = 0.85$ $4.64 \times .20 \times .20 \times .4 = 0.74$ $2.45 \times 2.10 \times .1 = .51$ $3.65 \times 3.30 \times .10 = 1.20$	3.98	cum	5984.5	23818.31
4	Brick work with 1st class bricks in cement mortar(6:1) page no 35 item no.22 (a) (b) 2012 $2 \times (2.25 + 1.30) \times 1.20 \times .25 = 2.13$	2.13	cum	6629.4	14120.62
5	125 mm thick brickwork with 1st class bricks in cement mortar 1:4 page no. 37 item no, 29 2012 $2 \times 2.5 + 2.10 \times 1.20 = 11.04$	11.04	sqm	872	9626.88
6	Hires & labour charges for shuttering with centering & necessary staging up to 4 meter using approved stout props & thick hard wood planks completion of works (up to roof of ground floor) F) 25 Mm to 30 MM shuttering without staging in foundation Page no. 31 item no.12 a/2012	43.78	sq.m	369.5	16176.71

Sl.No.	Description	Quantity	Unit	Rate	Page-2 Amount
7	Supplying handling and binding and laying in position steel reinforcement of different dimension in cement concrete work i.e R.C.C. P.S.C etc..... complete as per drawing and direction of engineer in charge (a) for M.S. rounds/ torque steel page no-33 item no-15 a(i)/2012	320	kg	70.31	22499.2
8	10 Mm thick cement plaster with sand & cement mortar (4:1) with 1.5 Mm thick neat cement punningr page no. 198 Item no, 2.(ii)c)PWD Bldg 12	40.2	sqm	144.7	5816.94
9	Supply fitting fixing first quality ceramic tiles in wall....All complete page no 64 item no.30,Ba(i)/2012.a) on Wall b) on floor wall tiles : 11.04 sqm. 2(2.10+2.45) x 0.80 = 7.28 sqm.	18.32	sqm	859.6	15747.87
10	Supplying fitting fixing M.S. Gate... with all fitting i.e. Hasp bolt, hinge, pad lock, painting with red lead and aluminium paint.a) M.S.work in frame grating with round or square bar or m.s. flat etc.without Page no. 94 item no. 10 b) supplying of 1.5 mm thick m.sheet fitted and fixed one of both faces.Page no. 95 item no. 13. 2.10 x 0.90 = 1.89	1.89	sqm.	1324.6	2503.49
11	Supplying and laying chequered tiles of any shade & of approved quality..... Etc. Floor :- 2(2.80+3.00) x 0.60 = 6.96 sqm.	6.96	sqm.	905.8	6304.37
12	Cement wash with colour/lime etc. complete page 206 item 6 (b) & 204 item 3(b)	10	sqm.	34.1	341.00
13	Supplying best indian reinforcement wire safety glass six mm thick. Including all complete fitted and fixing with theak glazing bit p-219 item - 6,	4.55	sqm	2427.8	11046.49
14	Applying acrylic emulsion approved quality paint on walls and ceiling All complete. Luxury quality p-215,19(ii) 5740.00sft - 20% of 5470 = 1148 sft + 3 x 1460.00 sft= 5528.00sft = 514.10 say 514.00 sqm - 239.41= 274.59 sqm say 275.00 sqm	2.50	sq.m	76.90	192.25
	Applying exterior grade acrylic primer of approved quality on plastered or concrete surface..... all complete. P-208,1-15 (b) 28' x 205'=5740 sft= 533.82 say 534.0 sqm. - 239.41= 294.59 say 295.00 sqm.	2.50	sq.m	47.67	119.18

Sl.No.	Description	Quantity	Unit	Rate	Page-3 Amount
16	Protective and decorative acrylic exterior emulsion paint..... all complete. P-210,I-19(b)	2.50	sq.m	89.2	223.00
17	Priming one coat on tumber and plastered surface with synthetic oil bound primer of approved quality All complete. P-13 I-7(a)	2.50	sqm	41.5	103.75
18	Priming one coat on steel surface with synthetic oil bound primer of approved quality All complete. P-13 I-7(b)	2.50	sqm	30.4	76.00
19	2 Nos. CFL lamp with switch, plug,4 Nos. 15 A Multiple plug,-2 nos. MCB 3 Nos. conduits,5.00 m wire- 5 Mtrs,-1.5 mm. . Main line wire 2 core - 4mm - 5.00 mtrs.	1 set	L.S.	1 set	2500.00
20	one 1/2 H.P. crompton make monoblock pump	1 set	L.S.	1 set	2500.00
21	PVC O.H. reservoir 500 ltr.	1 set	L.S.	1set	2000.00
					7402.75
				Rs.	139855.39
				Rs.	139855.00

Phalakarthy
4/1/13
Sub-Asstt. Engineer
Baranagar Municipality

[Signature]
4/1/13
Assistant Engineer
Baranagar Municipality

[Signature]
5/1/13
Chairman
Baranagar Municipality

$$x + \frac{4x}{100} = 139855.00$$

$$\frac{100x + 4x}{100} = 139855.00$$

$$104x = 13985500$$

$$x = \frac{13985500}{104}$$

Where 'x' = Put to tender = 134475.96

cess 1% = 1344.76

Contingency 3% = 4034.28

Total amount = 139855.00

Put to tender amount = 134475.96

Soig = 134476.00

[Signature]

23

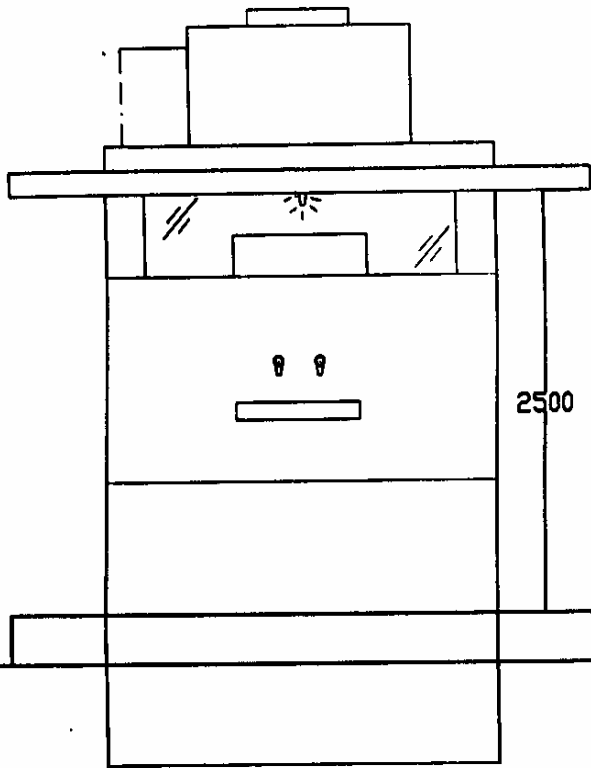

JAL SATRA

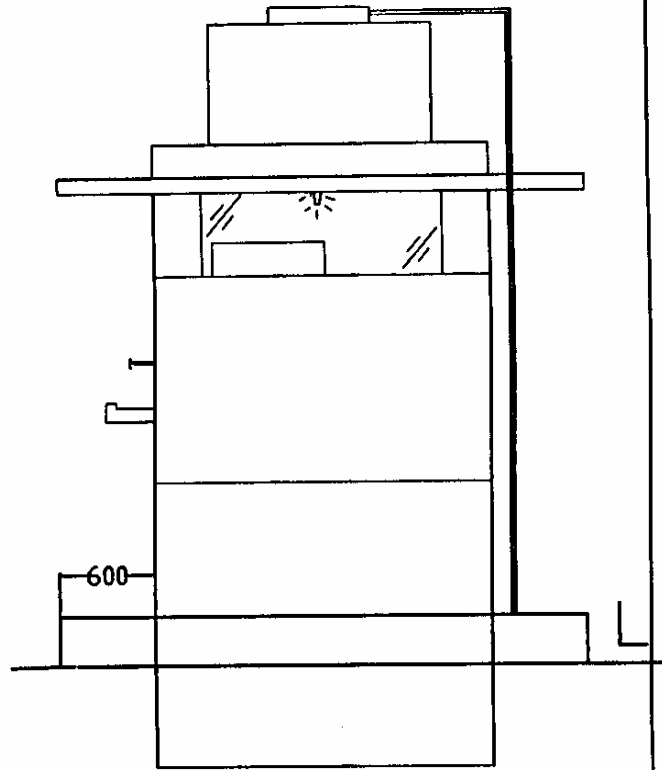

SIDE VIEW

LEGEND:

1. WALL FOR RESV.-250
2. OUTER WALL-125
3. R.C.C ROOF-100
4. REBAR- FE.500
5. PVC. D.H. TANK 500 LTR.
6. IN WINTER NORMAL WATER..

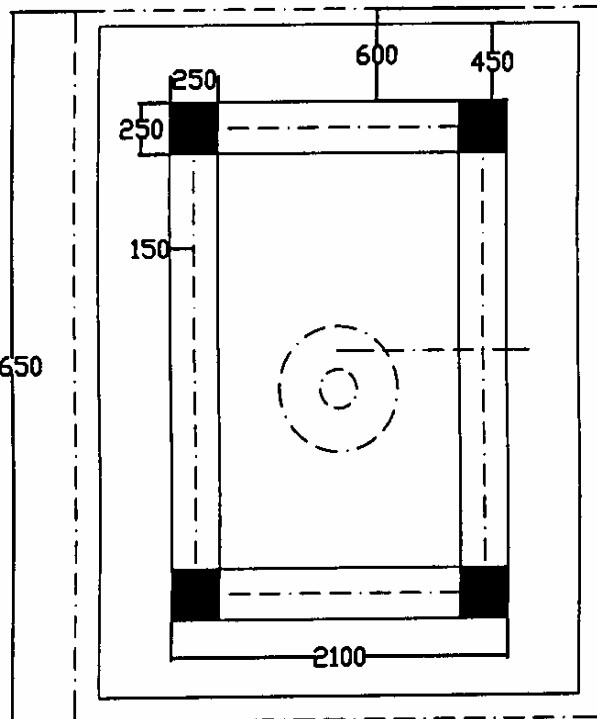

SECTIONAL PLAN

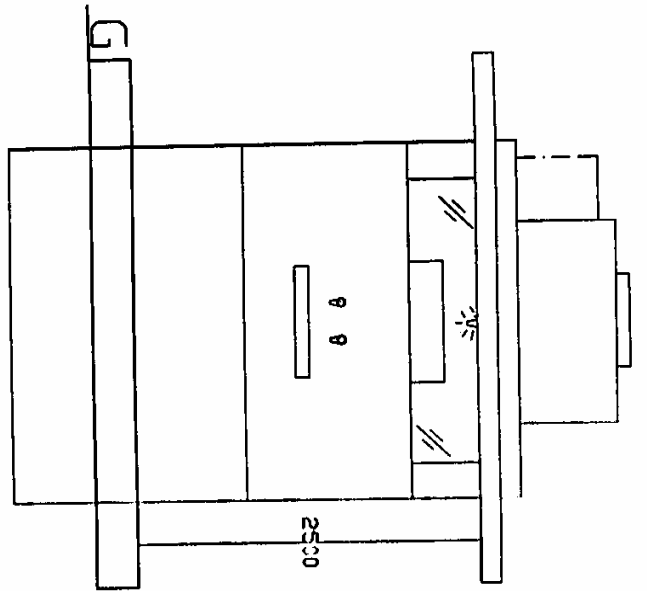

JAL SATRA

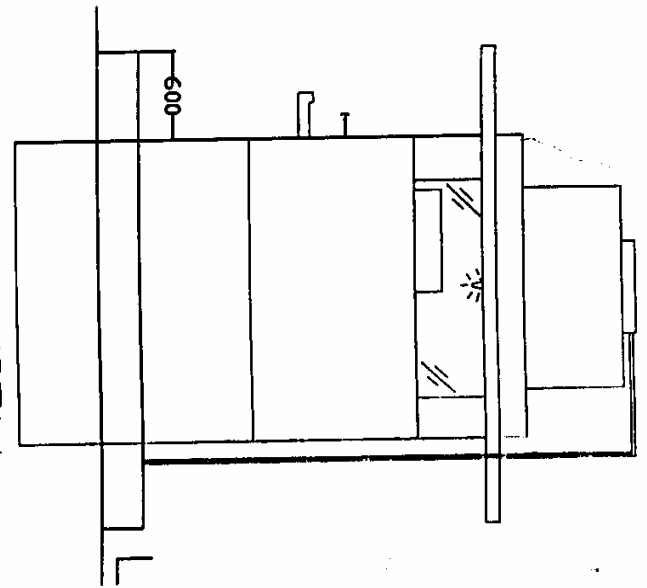

SIDE VIEW

LEGEND:

1. WALL FOR RESV.-250
2. OUTER WALL-125
3. R.C.C RDDF-100
4. REBAR- FE.500
5. PVC. DI. TANK 500 LTR.
6. IN WINTER NORMAL WATER..

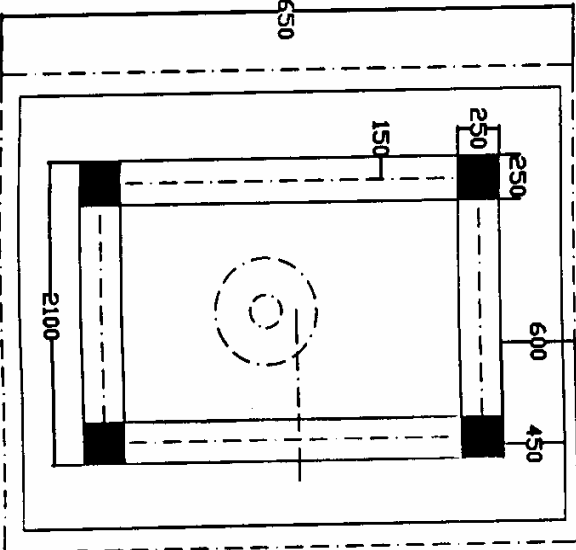

RECTANGULAR DI ANI

Amal
4/1/13

Drawn
5/1/13.